



# S.P. UNITED INDUSTRY SDN. BHD.

(Company No.: 368524 W)



ISO Cert No.: KLR0403952  
PED Cert No. 0038/PED/MUM/101009/1

## ASTM A403 ASME B16.9

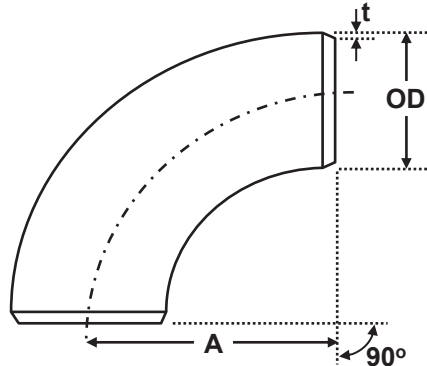

### 90° Long Radius Elbows

Unit : inch

Nominal Pipe Size	Outside Diameter (OD)	Wall Thickness (t)		Center to End (A)	Weights (Kg)	
		Sch 10S	Sch 40S		Sch 10S	Sch 40S
1/2"	0.84	0.083	0.109	1.50	0.060	0.076
3/4"	1.05	0.083	0.113	1.50	0.070	0.076
1"	1.32	0.109	0.133	1.50	0.156	0.160
1-1/4"	1.66	0.109	0.140	1.88	0.201	0.253
1-1/2"	1.90	0.109	0.145	2.25	0.279	0.363
2"	2.38	0.109	0.154	3.00	0.470	0.651
2-1/2"	2.88	0.120	0.203	3.75	0.786	1.290
3"	3.50	0.120	0.216	4.50	1.160	2.020
4"	4.50	0.120	0.237	6.00	2.000	3.840
5"	5.56	0.134	0.258	7.50	3.460	6.510
6"	6.62	0.134	0.280	9.00	4.960	10.100
8"	8.62	0.148	0.322	12.00	9.550	20.300
10"	10.75	0.165	-	15.00	16.600	-
12"	12.75	0.180	-	18.00	25.800	-



**S.P. UNITED INDUSTRY SDN. BHD.**

(Company No.: 368524 W)



ISO Cert No.: KLR0403952  
PED Cert No.: 0038/PED/MUM/101009/1

## ASTM A403 ASME B16.9

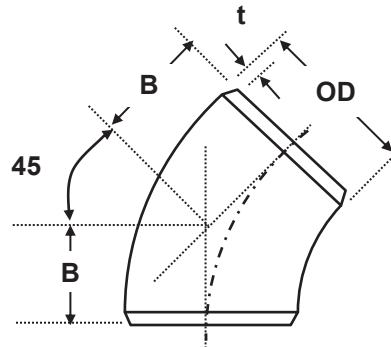

### 45° Long Radius Elbows

Unit : inch

Nominal Pipe Size	Outside Diameter (OD)	Wall Thickness (t)		Center to End (B)	Weights (Kg)	
		Sch 10S	Sch 40S		Sch 10S	Sch 40S
1/2"	0.84	0.083	0.109	0.62	0.030	0.038
3/4"	1.05	0.083	0.113	0.75	0.030	0.038
1"	1.32	0.109	0.133	0.88	0.078	0.095
1-1/4"	1.66	0.109	0.140	1.00	0.101	0.126
1-1/2"	1.90	0.109	0.145	1.12	0.140	0.182
2"	2.38	0.109	0.154	1.38	0.235	0.326
2-1/2"	2.88	0.120	0.203	1.75	0.393	0.645
3"	3.50	0.120	0.216	2.00	0.580	1.010
4"	4.50	0.120	0.237	2.50	1.000	1.920
5"	5.56	0.134	0.258	3.12	1.730	3.260
6"	6.62	0.134	0.280	3.75	2.480	5.050
8"	8.62	0.148	0.322	5.00	4.740	10.200
10"	10.75	0.165	-	6.25	8.300	-
12"	12.75	0.180	-	7.50	12.900	-